

Specifications on communication of J-chip Reader

08/07/2008 Rev. 1.1

MicroTalkSystems Corp.

Contents

Supported communication protocol.....	3
Communication of TCP/IP	4
The number of connection and connection mode.....	4
Establishment and disconnect of TCP/IP connection	4
Establishment of connection when "Client" was selected in type of connection.....	4
Establishment of connection when "Server" was selected in type of connection.....	4
Disconnect of the connection.....	4
The function of Keepalive of TCP	4
Initial value of setting related to TCP/IP	4
Form of a Packet.....	4
Communication Command.....	5
N command (from Receiver to HOST)	5
S command (from HOST to Receiver)	5
E command (from HOST to Receiver)	5
D command (from Receiver to HOST)	5
Format of a Tag data	6
About Serial communication	7
Communication method	7
Specifications	7
Form of a Packet.....	7
Communication Command	7
Request of tag data (Number desired to be obtained shall be appointed.).....	7
Request of tag data (Index to be appointed)	8
Request of tag data (continuous sending & stop continuous sending.)	8
Request for re-execution of request command of tag data which received at the end.	9
Request of reset for transmitted index	9
Command of Measuring Clock Setting.....	9
Request of the information of the receiver	10
Format of a Tag data	11
Specifications on communication Appendix	12
Acquisition of information	12
Acquisition of information of time relationship.....	12
Acquisition for information of the receiver	12
Acquisition of network information of receiver.....	12
Acquisition of log information	13
Acquisition of information of measurement	13
Information of connection.....	13
Acquisition of serial	14
Setting.....	15
Set of Time	15
Set of reservation time.....	15
Cancel of reservation time	15
Set of PCID.....	16
Set of tagprefix	16

Set of serial.....	16
Set of TEL No. when dialout	17
Set of Holding time	17
Set of Measure mode	17
Set of Device name of receiver	17
Set of Network of receiver.....	18
Set port which waiting connection of receiver	18
Set of Connections of receiver	18
Set of GPS Time offset	19
Set of System time of LINUX(OS).....	19
The reboot of the receiver.....	19
Behavior	20
Update of the log file.....	20
Communication of Tag Cheker and PC	21
Communication method	21
Specifications	21
Data Format	21
Note	21

Supported communication protocol

The J-chip receiver supported following communication protocol.

1. TCP/IP (8spots)
2. Serial communication

The TCP/IP communication (8 spots) and serial communication are able to connect simultaneously as it manages independently.

Communication of TCP/IP

The number of connection and connection mode

The maximum number of access point is 8 spots and each access points can select the type of connection (TCP Server TCP Client) separately.

The measurement data is managed in eight individual spots.

Establishment and disconnect of TCP/IP connection

Establishment of connection when "Client" was selected in type of connection.

When it becomes possible the connection of TCP/IP, the receiver (TCP Client) issues the request of connection (connect) to the host set in advance until the connection succeeds.

The receiver issues the request of connection(connect) similarly issued when TCP/IP disconnected.

The distance of issue is about 5 second.

The host waits for the request of connection of the receiver in the port specified in advance.

Establishment of connection when "Server" was selected in type of connection.

The receiver (TCP server) waits for the request of connection from the host in the port set in advance when it becomes possible the connection of TCP/IP.

The host issues the request of connection to the receiver specified in advance.

Disconnect of the connection

The connection of TCP/IP disconnect by judging the host side.

The receiver sends "N command (receiver name notification)" within five seconds when the connection of TCP/IP establishes it, the host separates the receiver by this receiver name.

In case of the same receiver name already exists, the previous connection is disconnect and it gives priority to a new connection.

The host disconnects the connection of TCP/IP when the host doesn't receive "N command (receiver name notification)" within five seconds.

The function of Keepalive of TCP

The receiver activate the Keepalive function, and the interval is 2 minutes, and it is judged that it disconnects the failure of five times.

Initial value of setting related to TCP/IP

Network	IP Address	192.168.2.211	
	Net Mask	255.255.255.0	
	Default Gateway	192.168.2.254	
	Listen Port	54321	
Conection1 Use			Conection2-8 Not Use
	Connection Type	TCP Client	
	Remote IP Address	192.168.2.1	
	Remote Port	12345	

Form of a Packet

A packet consists of ASCII character strings and a <CR>(carriage return=0x0d) is "terminated".

Communication Command

N command (from Receiver to HOST)

Nhhhhx-----x<cr>

To send (Data index number (hhhh) to be sent) next time and name (x---x) of Receiver.

'hhhh' is character strings in hexa-decimal with fixed 4 digits.(0000 to FFFF)

'x-----x' is ASCII character strings extendable up to 32 characters(max.).

Receiver send 'N command' upon finishing connection with successfully.

If host does not receive N command within 10 second, host will cut the connection.

Note: About (Data index number to be sent)

In case that it sent the number up to '0010', 'hhhh' will be '0011'.

Upon turning on power switch, if it has not started measuring, or if it has not read any tag data after start measuring, it will be '0000'.

S command (from HOST to Receiver)

Shhhh<cr>

To let Receiver start sending data from Data index number 'hhhh'.

In case that it has already started sending data, data index number shall be altered by 'hhhh'.

'hhhh' is character strings in hexa-decimal with fixed 4 digits. (0000 - FFFF)

Note: Processing at Receiver side.

It will not change Pointer which manage sending data at that time when (Data index number -1) appointed by S command does not exist at that time.

It will change Pointer at that time when Data index number is '0000' appointed by 'S command'.

It will not send data unless it receives S command from HOST after successful connection and issuing 'N command'.

E command (from HOST to Receiver)

E<cr>

To let Receiver stop sending data.

If it stops sending data, it will not do anything.

D command (from Receiver to HOST)

Dx-----x<cr>

Receiver will send tag data to HOST up to the time when it receives 'E command' or it cuts connection since it receives 'S command' after successful connection.

'x-----x' is Tag data.

Format of a Tag data

'J003D5A 00:56:50.7005 11 10000 '

a b c d e f g h

a:Tag ID	7 bytes (XFFFFFF X:A-Z FFFFFFF:000000-FFFFFF)
b:Measured Time	12 bytes (_hh:mm:ss.mm)
c:PC_ID	2 bytes (XX:01-99)
d:N/A	2 bytes (_1 fixed)
e: Number of days elapsed	1 byte (X:0-9)
f:Same ID sequence number	3 bytes (XXX: __1-255) Number of lap
g:Data index number	4 bytes (XXXX:0000-FFFF)
h: N/A	6 bytes (space 6)

Total 37 bytes

Tag ID

'X' (A-Z) is selectable on System Option in WEB menu.

'FFFFFF' is own individual No. of Tag.

Measured Time

'_hh:mm:ss.mm' hh:Hour mm: Minute ss:Second mm: Milli- second

PC_ID

'X'X (01-99) is selectable on System Option in WEB menu.

Number of days elapsed

Number of date that passed while measuring it were added to the tag data.

The count of number of date is "0" when the measurement is started then increase count of date one by one(+1) every time it changes from 23:59:59 into 00:00:00 during measurement.

About Serial communication

Communication method

RS232C

Specifications

Transfer speed	4800,9600,19200,38400(Selectable on System Option in WEB menu.)
Length of data	8 bits
Stop bit	1 bit
Flow control	Nil
Parity	Nil

Form of a Packet

A packet consists of ASCII character strings and a <CR>(carriage return=0x0d) is “terminated”.

Communication Command

Request of tag data (Number desired to be obtained shall be appointed.)

Command	'Desired number to be obtained' <cr> Desired number to be obtained is '1-9'.
Explanation	This is a command which requests desired numbers of tag data.
Response	'x-----x (tag data)'<cr> Desired numbers of tag data shall be sent. In case that the number of stored data is less than desired numbers to be obtained (1 to 9) by command, '*'(asterisk)<cr>' shall be sent.
Example: Case 1	In case of 10 owned tag data which has not been sent in response to command '1<cr>', send 1 pc of tag data. 'x-----x (tag data)'<cr>
Case 2	In case of 10 owned tag data which has not been sent in response to command '3<cr>', send 3 pcs of tag data. 'x-----x (tag data)'<cr> 'x-----x (tag data)'<cr> 'x-----x (tag data)'<cr>
Case 3	In case of no owned tag data which has not been sent in response to command '1<cr>', send only *<cr>. '*(asterisk)<cr>'

Case 4 In case of no owned tag data which has not been sent in response to command '3<cr>', send only *<cr>.

*(asterisk)<cr>'

Case5 In case of 3 tag data which has not been sent in response to command '9<cr>', 3 pcs of tag data and *<cr>.

'x-----x (tag data)'<cr>

'x-----x (tag data)'<cr>

'x-----x (tag data)'<cr>

*(asterisk)<cr>'

Request of tag data (Index to be appointed)

Command: Rxxxx<chk><cr>

'xxxx' is character strings in hexa-decimal with fixed 4 digits. (0000-FFFF)
<chk> is CheckSum of 2bytes : This makes lower 1 byte of total sum of 'Rxxxx'
(total 5 bytes) into character strings in hexa-decimal (16) numeration.

For Example : In case that 'xxxx' is '0000', this will be 'R000012<cr>'.

Explanation: This is a command which request tag data of data index number 'xxxx'.

Response 'x-----x (tag data)'<cr>
In case of no tag data at appointed index,
'*(asterisk)<cr>' shall be sent.

Request of tag data (continuous sending & stop continuous sending.)

Command: C<cr> 'C' is capitol letter.

Explanation: To start continuous sending tag data.

Response: No response.

Command: c<cr> 'c' is small letter.

Explanation: To finish continuous sending tag data.

Response: No response.

Receiver receive 'C' command then start continuous sending then it will ignore command except 'c' command.

Request for re-execution of request command of tag data which received at the end.

Command: R<cr>

Explanation: Receiver do the same process of request of tag data at the end (Number desired to be obtained shall be appointed, Index to be appointed) when receive this command.
A command to become an object are '1' – '9' and 'Rxxxx'.

Response: The same specification of response of tag data which received at the end.

Request of reset for transmitted index

Command: S<cr>

Explanation: To let the index number to be sent next to return to the top (0000).

Response: No response.

Command of Measuring Clock Setting

Command: Thhmmssnn <chk><cr>
hhmmssnn means hh (hour), mm(minute), ss(second),nn(millisecond)
It accept from '00000000' to '23595999'
<chk> is Check Sum of 2 bytes and lower 1 byte of total sum of 'Thhmmssnn'(total 9 byte) into character strings in hexa-decimal (16) numeration.
For Example : Command of setting to '12:00:00.00'
T12000000D7<cr>

Explanation: Setting of hour ,minute, second, millisecond to clock for measurement.

Response: No response

Caution: If this command send to receiver from PC during measurement, receiver will ignore this command because it is not available change the time of clock during measurement.

Receiver set time to clock for measurement by this command but it is not recognize the time difference between PC and receiver during communication and Host side will adjust such time difference.

Request of the information of the receiver

Command I<cr>

Explanation The command that request of IP address of the receiver, the version number of firm ware of the receiver and time information of measuring clock.

Response IP:xxx.xxx.xxx.xxx_Ver:y.yy.y_hh:mm:ss.nn_<chk><cr> '_(Underbar) is space.
'xxx.xxx.xxx.xxx' is IP address.
'y.yy.y' is version No.
'hh:mm:ss.nn' is measuring clock time.

<chk> is Check Sum of 2 bytes and lower 1 byte of total sum of
'IP:xxx.xxx.xxx.xxx_Ver:y.yy.y_hh:mm:ss.nn_'(total 42 bytes) into character
strings in hexa-decimal (16) numeration.

Format of a Tag data

'J003D5A 00:56:50.7005 11 10000 C8'
a b c d e f g h i

a:Tag ID	7 bytes (XFFFFFF X:A-Z FFFFFFF:000000-FFFFFF)
b: Measured Time	12 bytes (_hh:mm:ss.mm)
c:PC_ID	2 bytes (XX:01-99)
d:N/A	2 bytes (_1 fixed)
e: Number of days elapsed	1 byte (X:0-9)
f:Same ID sequence number	3 bytes (XXX: __1-255) Number of lap
g:Data index number	4 bytes (XXXX:0000-FFFF)
h: N/A	6 bytes (space 6)
i:Checksum	2 bytes

Total 39 bytes

Tag ID

'X' (A-Z) is selectable on System Option in WEB menu.

'FFFFFF' is own individual No. of Tag.

Measured Time

'_hh:mm:ss.mm' hh:Hour mm: Minute ss:Second mm: Milli- second

PC_ID

'X'X (01-99) is selectable on System Option in WEB menu.

Number of days elapsed

Number of date that passed while measuring it were added to the tag data.

The count of number of date is "0" when the measurement is started then increase count of date one by one(+1) every time it changes from 23:59:59 into 00:00:00 during measurement.

Checksum

This makes lower 1 byte of total sum (37 bytes) from 'a:' to 'h:' into character strings in hexa-decimal (16) numeration.

Specifications on communication Appendix

The command supports it with Receiver Version 4.00.0 after.

The command is same for both Network and RS.

The <chk> is check sum and it only use for RS.

Acquisition of information

Acquisition of information of time relationship

GT<chk><cr> Host to Receiver
GTdhhmmssnnMR<chk><cr> Receiver to Host

d The elapsed days of 0 – 9.
hhmmssnn hour minute second milisecond (milisecond is 10 milisecond unit)
M Element of setting of current time, 8 characters with fixed length.
0 No setting (The elapsed time from power ON)
1 Time when set with automatic time setting by GPS.
2 Time when set with manual time setting by GPS.
3 Time when it was set by T Commnad.
4 Time when it was set by the reservation time.
5 Time when it was set by manual fromk front panel of receiver.
R The current status of actual reservation time,1 character with fixed Length.
0 No reservation time.
1 The reservation time exist(wating signal of SYNC).

Acquisition for information of the receiver

GS<chk><cr> Host to Receiver
GSiipv-v,n-n<chk><cr> Receiver to Host

ii PC-ID 00-99 2characters with fixed length.
p Tagprifix A-Z 1 character with fixed length.
v-v version character string and variable length,8 character max.
, delimiter
n-n name of receiver with variable length,32 character max.

Acquisition of network information of receiver

GN<chk><cr> Host to Receiver
Gna-a,m-m,g-g<chk><cr> Receiver to Host

a-a IP address description of "." with variable length.
, delimiter
m-m Netmask description of "." with variable length.
, delimiter
g-g Default gate way description of "." with variable length.

Acquisition of log information

GL<chk><cr> Host to Receiver
GLsx-x,f-f,u-u<chk><cr> Receiver to Host

s	Status of measuring
0	do not measure.
1	Measuring
x-x	No. of log from atart,hexadecimal 8 character with fixed length.
,	delimiter
f-f	all size of data area with variable length. (MB unit)
,	delimiter
u-u	use size of data area with variable length. (MB unit)

Acquisition of information of measurement

GM<chk><cr> Host to Receiver
GMmnn<chk><cr> Receiver to Host

m	measuring mode.1 character with fixed length.
0	First time
1	Mid time
nn	Holding time. 00-60. 2 character with fixed length.

Information of connection

GC<chk><cr> Host to Receiver
GCp-p:channel0:channel1-chanel7<chk><cr> Receiver to Host
A port number awaiting connection and 8 channel information with connectable divide by ":"

p-p	Port No. which waiting connection of receiver with variable length.
-----	---

Descriptin of each channel.

msa-a,p-p	
m	connection mode.1 character fixed length.
0	unused
1	Receiver is client.
2	Receiver is server.
s	status of conection. 1 charcter with fixed length.
0	No connection
1	Connecting
a-a	IP address description of "." with variable length.
	"0.0.0.0" when receiver is server and no connection or unused.
,	delimiter
p-p	TCP port No. of connection up to 1-65535 with decimal variable length.
	"0" when receiver is server with no connection or unused.

Acquition of serial

GR<chk><cr>

Host to Receiver

GRb-b,mx-x<chk><cr>

Receiver to Host

b-b	baudrate. 4800 or 9600 or 19200 or 38400 with variable length.
,	delimiter
m	set of usage. 0 No modem 1 Modem Dialout 1 Modam Dialin
x-x	Tel No. 32 character with valiable length when modem Dialout.

Set of PCID

Ainn<chk><cr> Host to Receiver
Aix<chk><cr> Receiver to Host

nn PC-ID. 00-99 2 charcters fixed length.
x Result
0 Normal end
1 Failure(format is different,during measurement etc...)

This command is reflected promptly.

Set of tagprefix

APa<chk><cr> Host to Receiver
APx<chk><cr> Receiver to Host

a Tagprefix. A-Z 1 charcter fixed length.
x Result
0 Normal end
1 Failure(format is different,during measurement etc...)

This command is reflected promptly.

Set of serial

ARb-b,m<cr> Host to Receiver
ARx<cr> Receiver to Host

b-b specify baudrate.
4800 or 9600 or 19200 or 38400 with variable length.
, delimiter
m set of usage.
0 No modem
1 Modem Dialout
2 Modam Dialin
x Result
0 Normal end
1 Failure(format is different,during measurement etc...)

This command is reflected promptly.

This command does not support it by the serial communication.

Set of TEL No. when dialout

Ala-a<cr> Host to Receiver
ALx<cr> Receiver to Host

a-a TEL No. 32 characters with variable length.

x Result
0 Normal end
1 Failure(format is different,during measurement etc...)

This command is reflected promptly.

This command does not support it by the serial communication.

Set of Holding time

AHnn<chk><cr> Host to Receiver
AHx<chk><cr> Receiver to Host

nn Holding time. 00-60 2 characters with fixed length.

x Result
0 Normal end
1 Failure(format is different,during measurement etc...)

This command is reflected promptly.

Set of Measure mode

AMn<chk><cr> Host to Receiver
AMx<chk><cr> Receiver to Host

n Measure mode.1 character with fixed length.

0 Beginning time
1 Mid time

x Result
0 Normal end
1 Failure(format is different,during measurement etc...)

This command is reflected promptly.

Set of Device name of receiver

AEn-n<chk><cr> Host to Receiver
AEx<chk><cr> Receiver to Host

n-n Device name.32 characters with variable length.

x Result
0 Normal end
1 Failure(format is different,during measurement etc...)

This command is reflected after Re-boot up..

Set of Network of receiver

ANa-a,m-m,g-g<chk><cr> Host to Receiver
ANx<chk><cr> Receiver to Host

a-a	IP address description of "." with variable length.
,	delimiter
m-m	Netmask description of "." with variable length.
,	delimiter
g-g	Default gate way description of "." with variable length.
a-a	Device name.32 characters with variable length.
x	Result
0	Normal end
1	Failure(format is different,during measurement etc...)

This command is reflected after Re-boot up..

Set port which waiting connection of receiver

ASp-p<chk><cr> Host to Receiver
ASx<chk><cr> Receiver to Host

p-p	TCP port No. of connection. 1-65535 with variable length
x	Result
0	Normal end
1	Failure(format is different,during measurement etc...)

This command is reflected after Re-boot up..

Set of Connections of receiver

ACnma-a,p-p<chk><cr> Host to Receiver
ACx<chk><cr> Receiver to Host

n	Channel No. 0-7 1 charcter with fixed length.
m	Connection mode. 1 charcter with fixed length.
0	Unused
1	Receiver is client
2	Receiver is server
a-a	IP address description of "." with variable length. "0.0.0.0" when receiver is server and no connection or unused.
,	delimiter
p-p	TCP port No. of connection. 1-65535 with variable length
x	Result
0	Normal end
1	Failure(format is different,during measurement etc...)

This command is reflected after Re-boot up..

Set of GPS Time offset

AOshhmm <chk><cr> Host to Receiver
AOx<chk><cr> Receiver to Host

s	“+” (plus) or “-” (minus)
hh	Hour. 00-23 2 character with fixed length.
mm	Minuts. 00 or 15 or 30 or 45 with fixed length
x	Result
	0 Normal end
	1 Failure(format is different,during measurement etc...)

This command is reflected promptly.

Set of System time of LINUX(OS)

ADyyyymmddhhnnss<chk><cr> Host to Receiver
ADx<chk><cr> Receiver to Host

yyyy	Year 1970-2038 4 character fixed length.
mm	Month 01-12 2 character fixed length.
dd	Day 01-31 2 character fixed length
hh	Hour 00-23 2 characters fixed length.
nn	Minute 00-59 2 characters fixed length.
ss	Second 00-59 2 characters fixed length.
x	Result
	0 Normal end
	1 Failure(format is different,during measurement etc...)

This command is reflected promptly.

The reboot of the receiver

AZ<chk><cr> Host to Receiver
AZx<chk><cr> Receiver to Host

x	Result
	0 Normal end
	1 Failure(format is different,during measurement etc...)

This command is reflected promptly.

Behavior

Update of the log file

BL <chk><cr>

Host to Receiver

BLx<chk><cr>

Receiver to Host

x

Result

0 Normal end

1 Failure(Not during measurement ,Writing USB Memory etc...)

This command is effective only while measuring it.

The receiver close file which current measurement data stored when receive BL command during measurement then make new file for store.

In such case, the number of LAP(f) and number of index(g) in tag data reset to each 0 and 0000.

In case of write the data to USB memory after finished measurement, the file before the last BL command doesn't become an object of write to USB memory.

Format of a Tag data

```
'J003D5A 00:56:50.7005 11 10000 C8'
```

a b c d e f g h i

Example 1 :

In case of PC-ID start measurement by the receiver "1" and the BL command transmit twice from host during measurement.

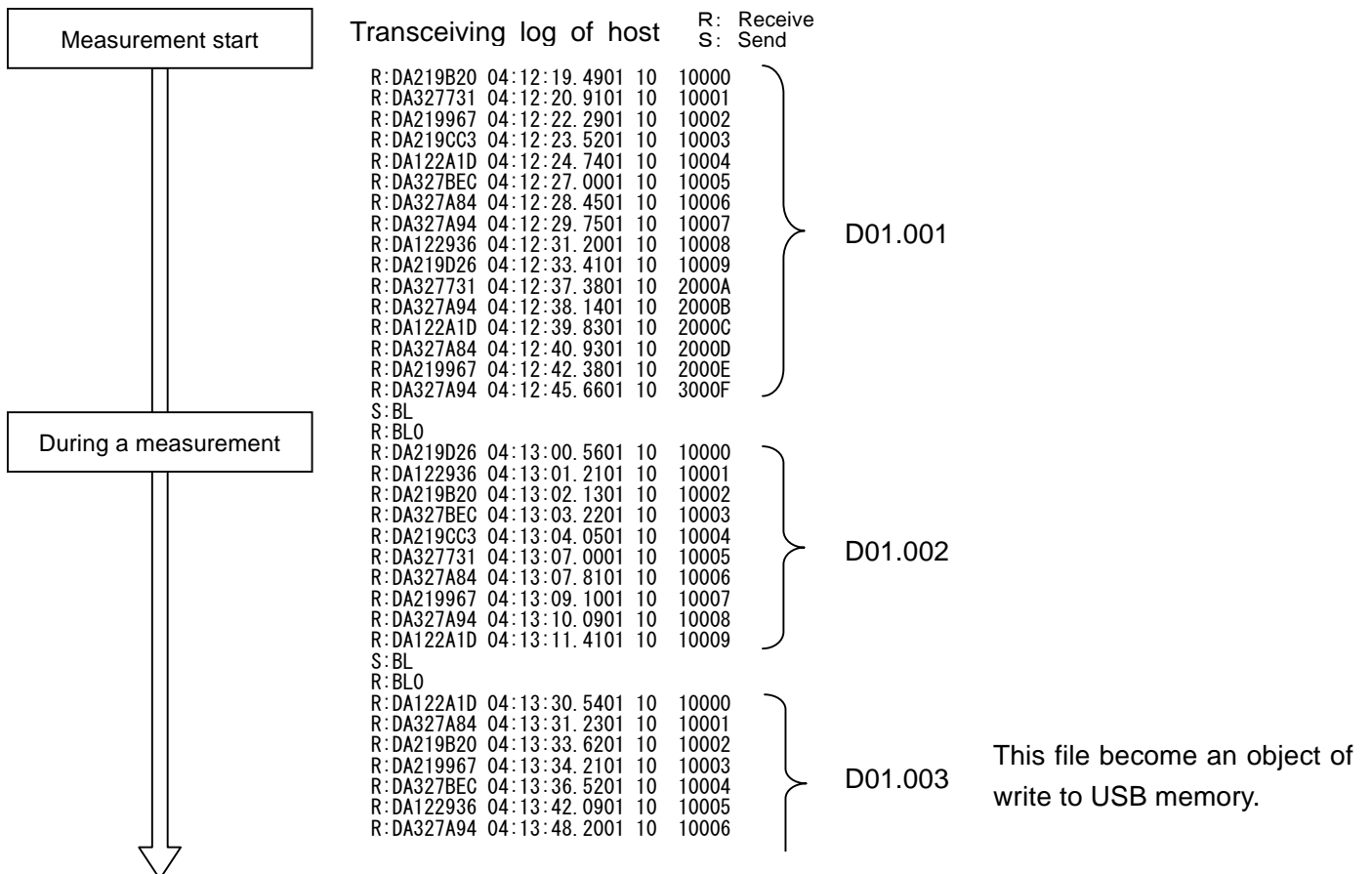

Communication of Tag Cheker and PC

Communication method

RS232C

Specifications

Transfer speed	9600
Length of data	8 bits
Stop bit	1 bit
Flow control	Nil
Parity	Nil

Data Format

XXXXXX_YYYYYY<CR><LF>

Code of Character : ASCII

'XXXXXX' is own individual No. of Tag. 6 character with fixed length.

'_' is space.

'YYYYYY' is Battery information. Three degrees indication : 'Charge' or 'OK____' or 'FULL__'
6 character with fixed length.

<CR> is Carriage return. (hex:0d)

<LF> is Line feed. (hex:0a)

Note

It is possible for PC to receive Data by Hiper-Terminal,standard attached software of MS Windows.

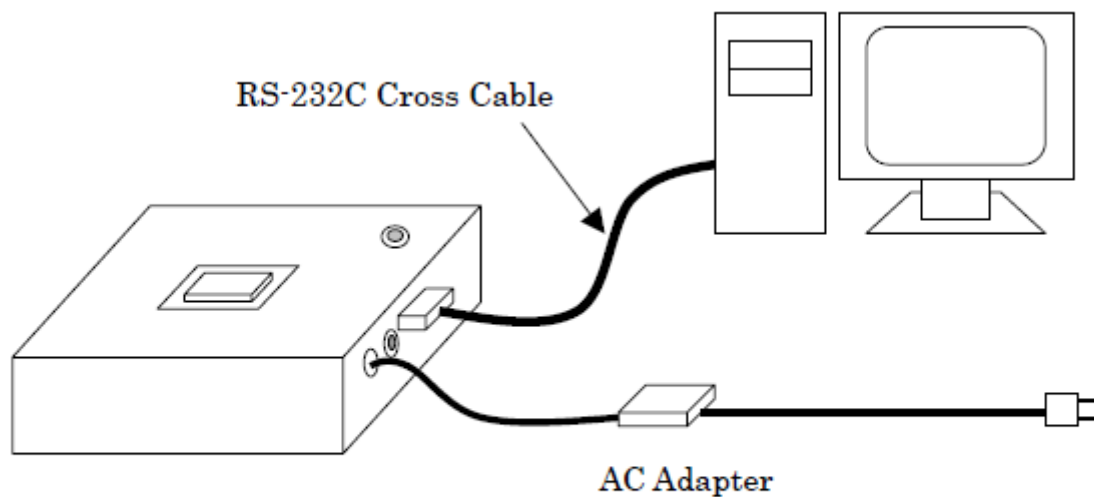

Example of connection